

# SR-10J type C

SWISS TYPE CNC AUTOMATIC LATHE

star

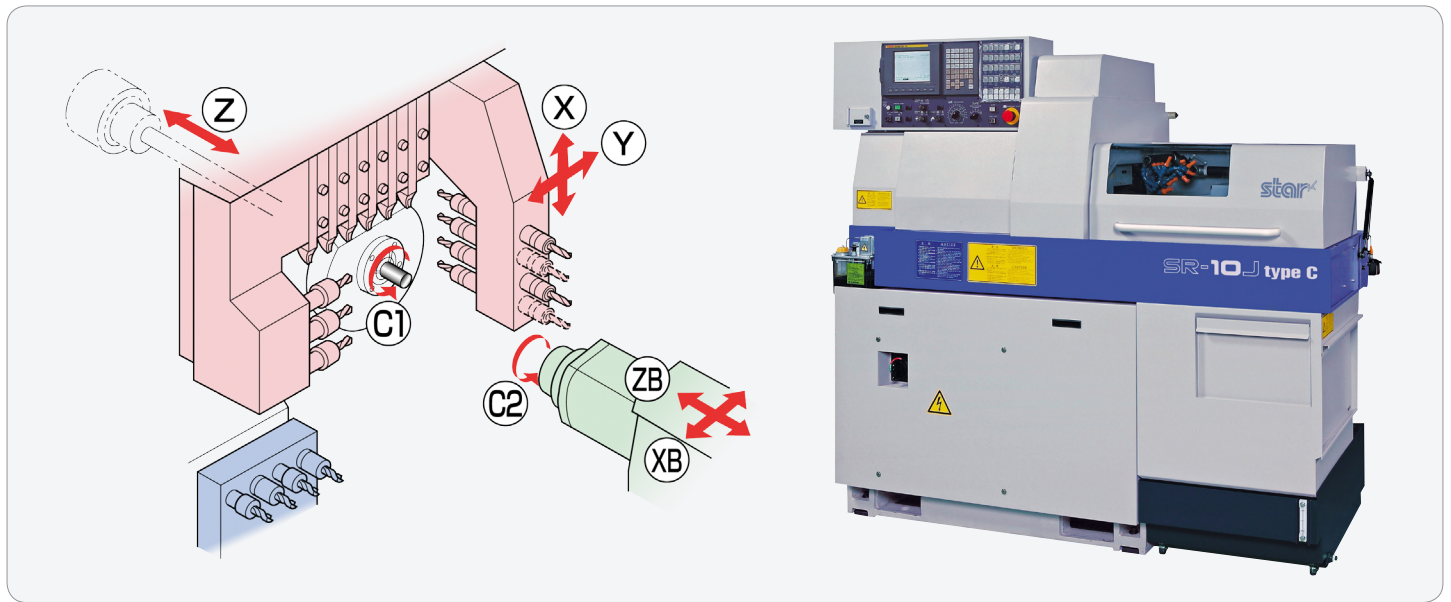

[View machine demo >](#)

[View case study >](#)

## Introducing the Advanced J-series small diameter machining model

- » C-axis is standard on both main and sub spindles.
- » Operation screen is easy to see/use with its 10.4 inch color display.
- » User-friendly NC; upgraded memory capacity, more help functions, etc.
- » Standard manual pulse generator that is useful for installation.

### High precision

- » The rigid tool post is equipped with a slanted sliding guideway.
- » Z-ZB synchronization, phase synchronization of the main/sub spindle.

### High functionality

- » 3-spindle drill unit for cross machining (standard).
- » Rear driven tool capabilities give greater overlapping options.

### High productivity

- » Minimum distance approach with the U-shaped tool post.
- » High-speed rapid traverse: 35m/min.
- » Independent tool post with driven tool capabilities.

### Space saving

- » Designed with small footprint of 775mm depth.

Rigid tool post with "slanted dovetail slideway structure". The tool post with Star's original "slanted dovetail slideway structure" improves the lifespan of cutting tools and maintains dimensional accuracy during continuous machining for long-periods.

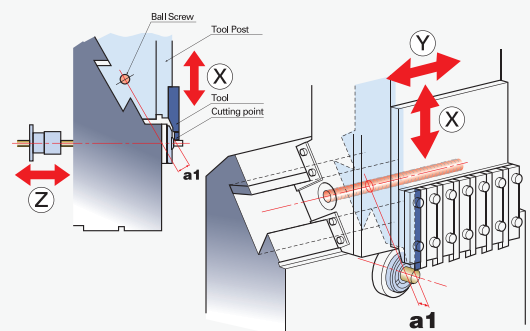

The Y-axis slideway of the tool post incorporates a slanted dovetail structure. The X and Y-axis slideways can be arranged in a pattern close to the cutting point, which improves machine rigidity. In addition, a straight line, passing through the ball screw center which is parallel to the Y-axis slideway and the cutting point are close to each other (a1), reducing the moment load caused by cutting resistance and thereby improving rigidity.



"With improved secondary machining capability and operability, the evolutionary advanced SR-10J is now on the market."

### Standard Machine Specifications

Item	Specifications	
Max. machining diameter	φ 10mm (25/64in)	
Max. headstock stroke	Stationary GB 135mm (5-5/16in) Revolving GB 105mm (4-9/64in)	
Tool	6 tools (□8mm) Front 4 tools Rear 4 tools	
4-Spindle sleeve holder	Number of tools	
	Max. drilling capability	φ6mm (15/64in)
	Max. tapping capability	M5×P0.8
Power driven att.	Number of tools	3 tools
	Max. drilling capability	φ4mm (5/32in)
	Max. tapping capability	M3×P0.5
Main spindle indexing angle	C-axis control	
Main spindle speed	Max.15,000min <sup>-1</sup>	
Main spindle motor	2.2kw(continuous)/3.7kw(15min./60%ED)	
Rapid feed rate	35m/min (X, Y, Z, XB, ZB)	
Power-driven att. spindle speed	Max.10,000min <sup>-1</sup>	
Power-driven att. drive motor	0.5kw	
Coolant tank capability	89 ℓ	
Dimensions (W×D×H)	1,865×775×1,695mm	
Center height	1,050mm	
Weight	1,400kg	
Power consumption	3.1KVA	

### Standard Accessories and Functions

- CNC unit (FANUC 32i-B)
- Cabinet & Operation panel
- 10.4-inch color LCD display
- Manual pulse generator
- Pneumatic unit
- Stand alone type coolant tank
- Coolant level detector (lower limit)
- Automatic centralized lubrication unit (with level detector)
- Door interlock system
- Main collet (select from tooling system)
- Cs contouring control (main/sub spindle)
- Spindle clamp unit (Main/Sub)
- 6-station tool holder (□8mm)
- 4-Spindle sleeve holder
- Drive system for power-driven attachment
- Back working Attachment
- Drive unit for power-driven attachment B
- Sub collet (select from tooling system)
- Sub spindle air purge unit
- Sub spindle air blow unit
- Parts ejection detector
- Broken cutoff tool detector
- Leveling bolt & leveling pad
- Work light
- Leakage breaker (Rated current sensitivity: 30mA)
- Operation tool kit

### Optional Accessories and Functions

- Main spindle inner tube 6mm
- Stationary guide bush unit
- Rotary guide bush drive unit
- Rotary magic guide bush unit
- Air purge unit
- Coolant flow detector
- Automatic barfeeder interface
- Water removal unit
- Tool for maintenance
- 4-Spindle unit for back working (For stationary tools at back)
- Parts separator unit A
- Transformer CE marking specifications
- Parts conveyor
- Compliant with the RS-232C interface
- Warning light

### Backworking Attachment Specifications

Item	Specifications	
Max. chucking diameter	φ 10mm (25/64in)	
Max. length for front ejection	70mm (2-3/4in)	
Max. parts projection length	20mm (25/32in)	
Number of tools	Stationary tool : 4tools / Power driven tool : Max.2tools	
Back 4-Spindle unit	Max. drilling capability Stationary tool	φ4mm (5/32in)
	Max. drilling capability Power driven tool	φ4mm (5/32in)
	Max. tapping capability Stationary tool	M3×P0.5
Max. tapping capability Power driven tool	M3×P0.5	
Sub spindle indexing angle	C-axis control	
Sub spindle speed	Max.10,000min <sup>-1</sup>	
Sub spindle motor	0.55kw(continuous)/1.1kw(15min./50%ED)	

Note)  
The machining capacities apply to SUS303 material. The machining capacities may differ from listed values depending on the machining conditions, such as the material to be machined or the tools to be used.

### External Dimensions & Floor Space

unit: mm(ft)

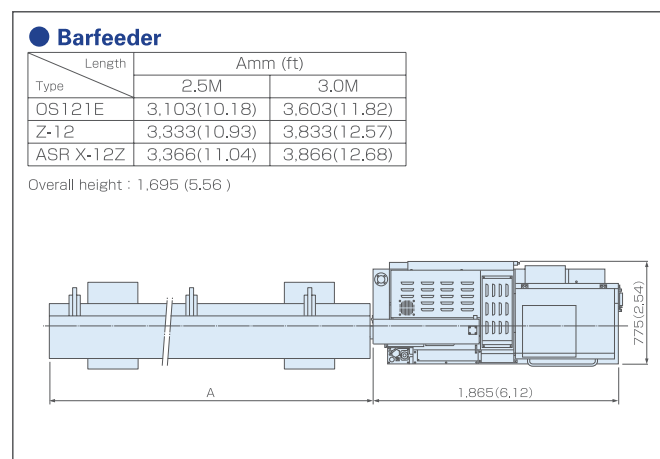

※Design features, specifications and technical execution are subject to change without prior notice.

※This product is an export control item subject to the foreign exchange and foreign trade laws. Thus, before exporting this product, or taking it overseas, contact your STAR MICRONICS dealer.

## Star Micronics GB Limited



Chapel Street, Melbourne,  
Derbyshire, DE73 8JF, U.K.

Tel:  
01332 864455

Email:  
sales@stargb.com

Web:  
www.stargb.com